

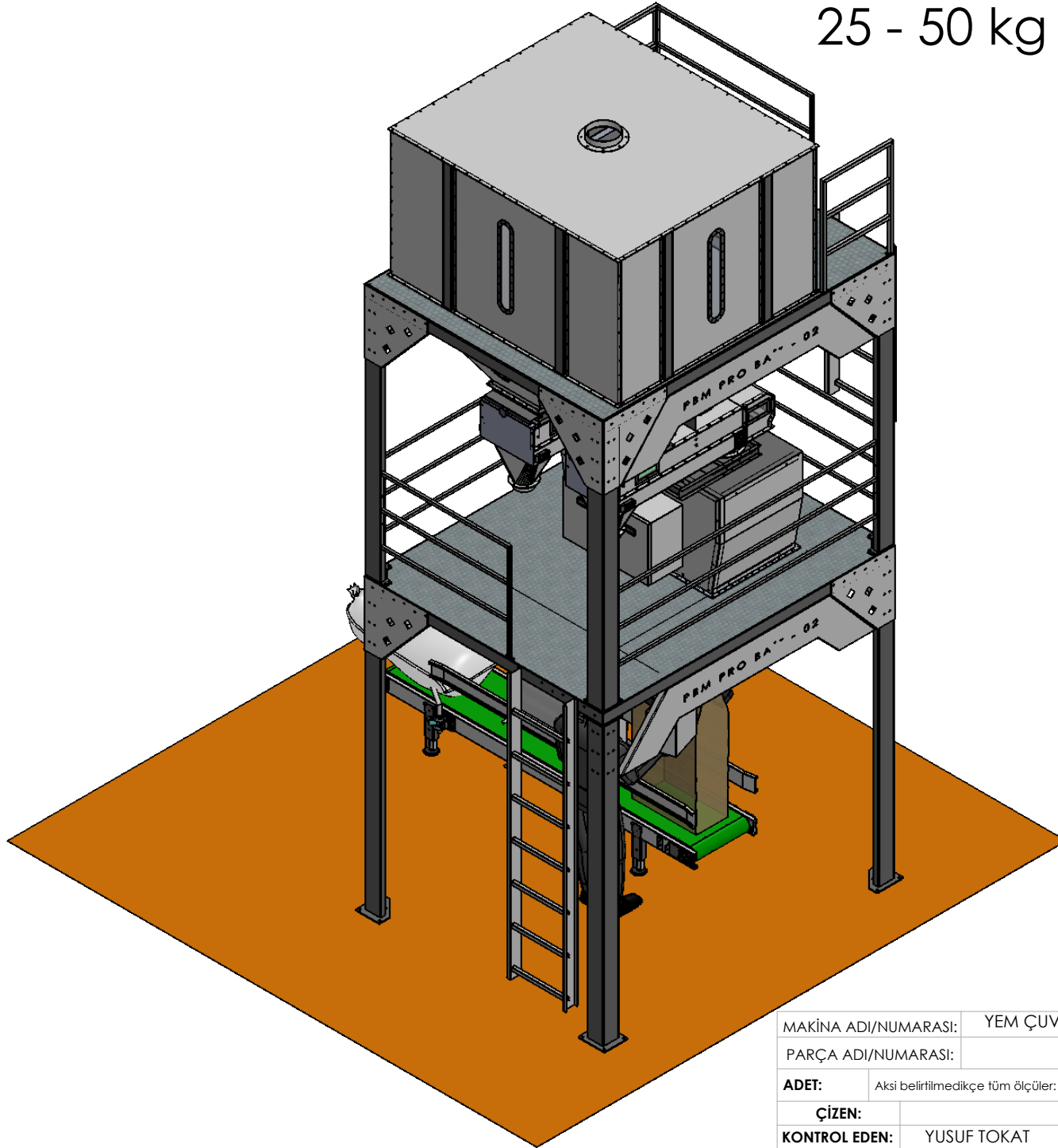



25 - 50 kg YEM ÇUVALLAMA



MAKİNA ADI/NUMARASI:	YEM ÇUVALLAMA HATTI	SAYFA	A4	YASAL SAHİP:	
PARÇA ADI/NUMARASI:		ÖLÇEK	1:100		
ADET:	Aksi belirtilmedikçe tüm ölçüler: mm	TARİH	MALZEME:	Material"	Revizyon: İZDÜŞÜM YÖNTEMİ: 3.AÇI
ÇİZEN:		11.07.2023	AĞIRLIK:	Weight"	
KONTROL EDEN:	YUSUF TOKAT	11.07.2023	YÜZEY:	Finish"	
ONAYLAYAN:	YUSUF TOKAT	11.07.2023	RESİM NO:		

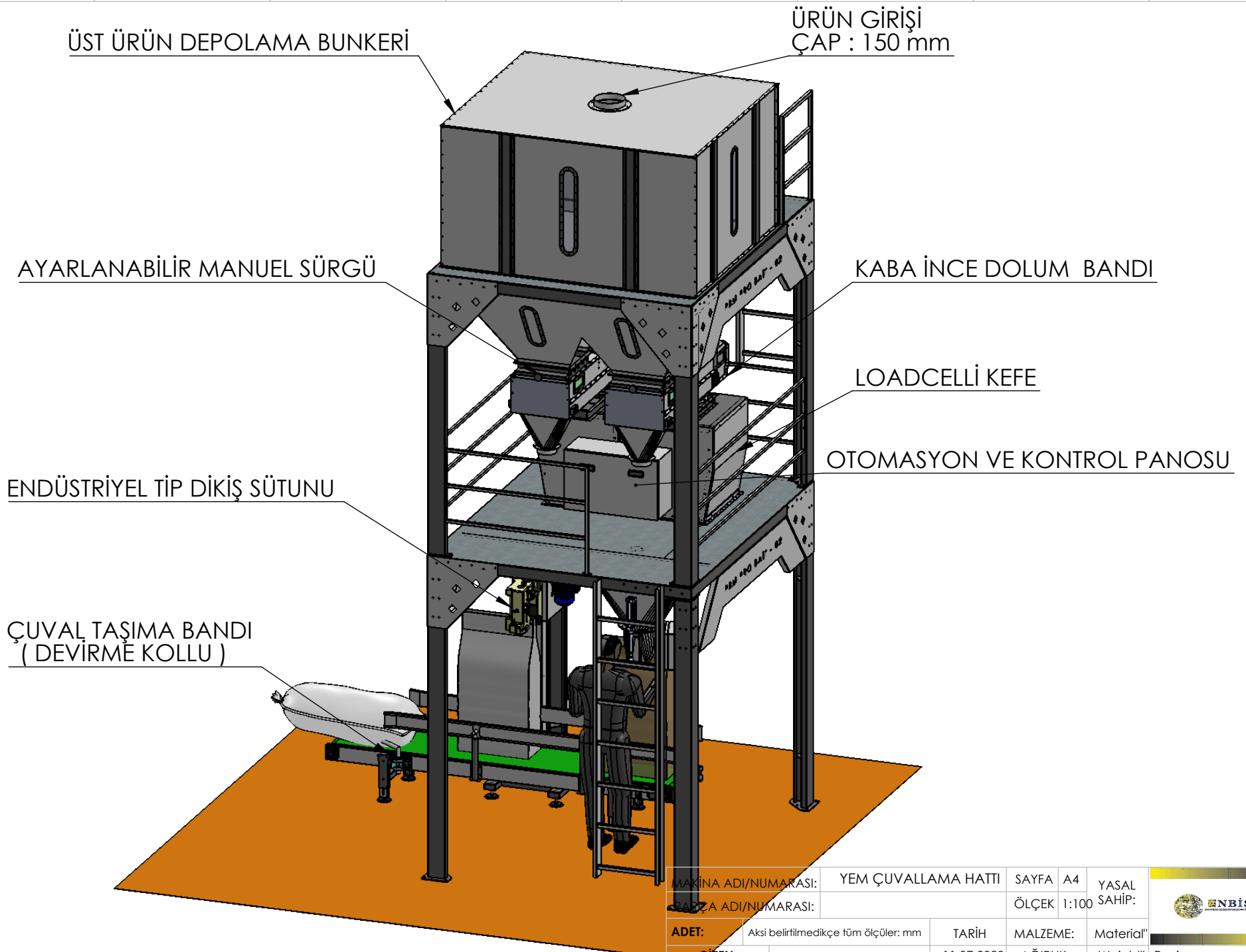

İZOMETRİK GÖRÜNÜM

MAKİNA ADI/NUMARASI:	YEM ÇUVALLAMA HATTI	SAYFA	A4	YASAL SAHİP:	
PARÇA ADI/NUMARASI:		ÖLÇEK	1:100		
ADET:	Aksi belirtilmedikçe tüm ölçüler: mm	TARİH	MALZEME:	Material"	Revizyon: İZDÜŞÜM YÖNTEMİ: 3.AÇI
ÇİZEN:		11.07.2023	AĞIRLIK:	Weight"	
KONTROL EDEN:	YUSUF TOKAT	11.07.2023	YÜZEY:	Finish"	
ONAYLAYAN:	YUSUF TOKAT	11.07.2023	RESİM NO:		

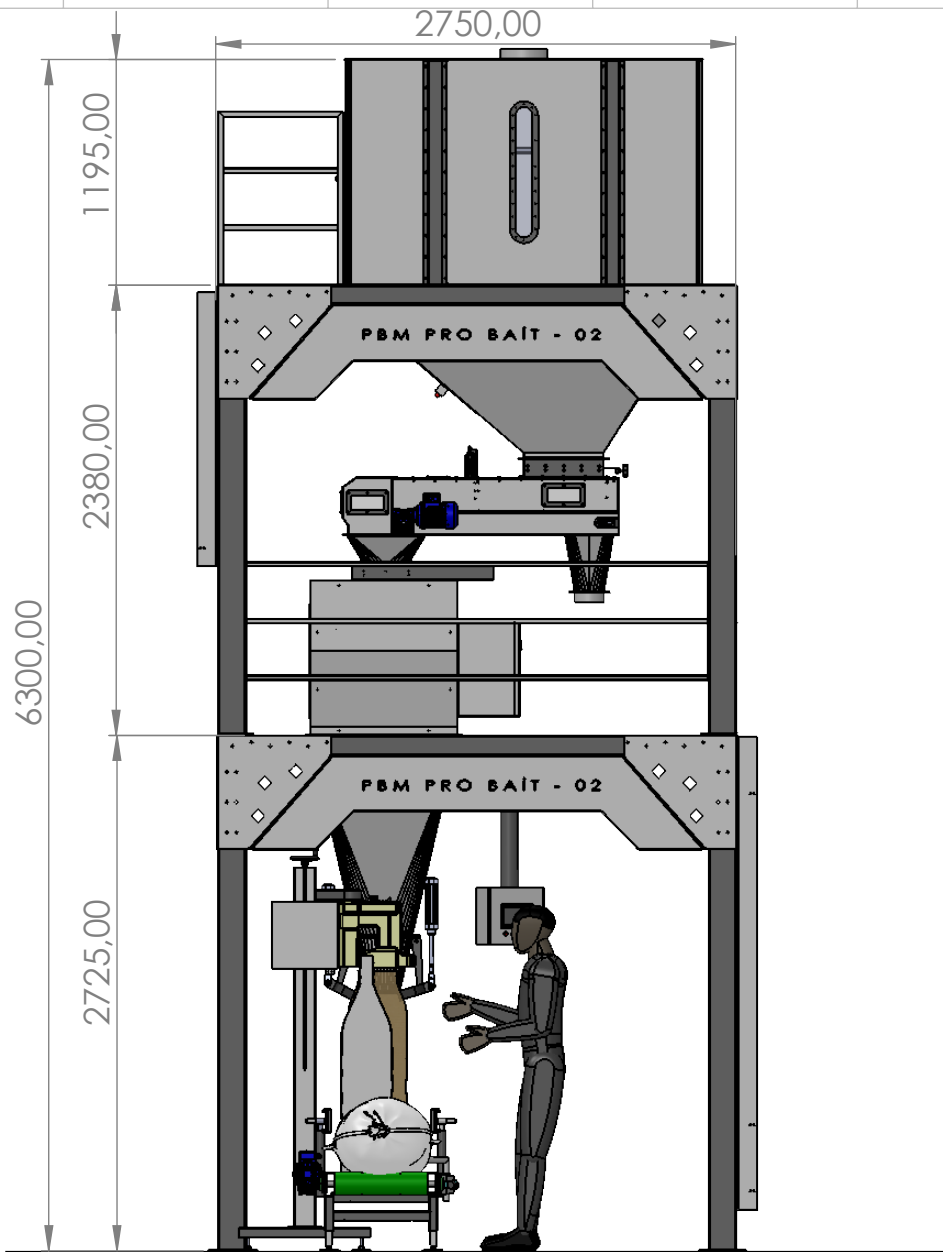

YAN GÖRÜNÜM

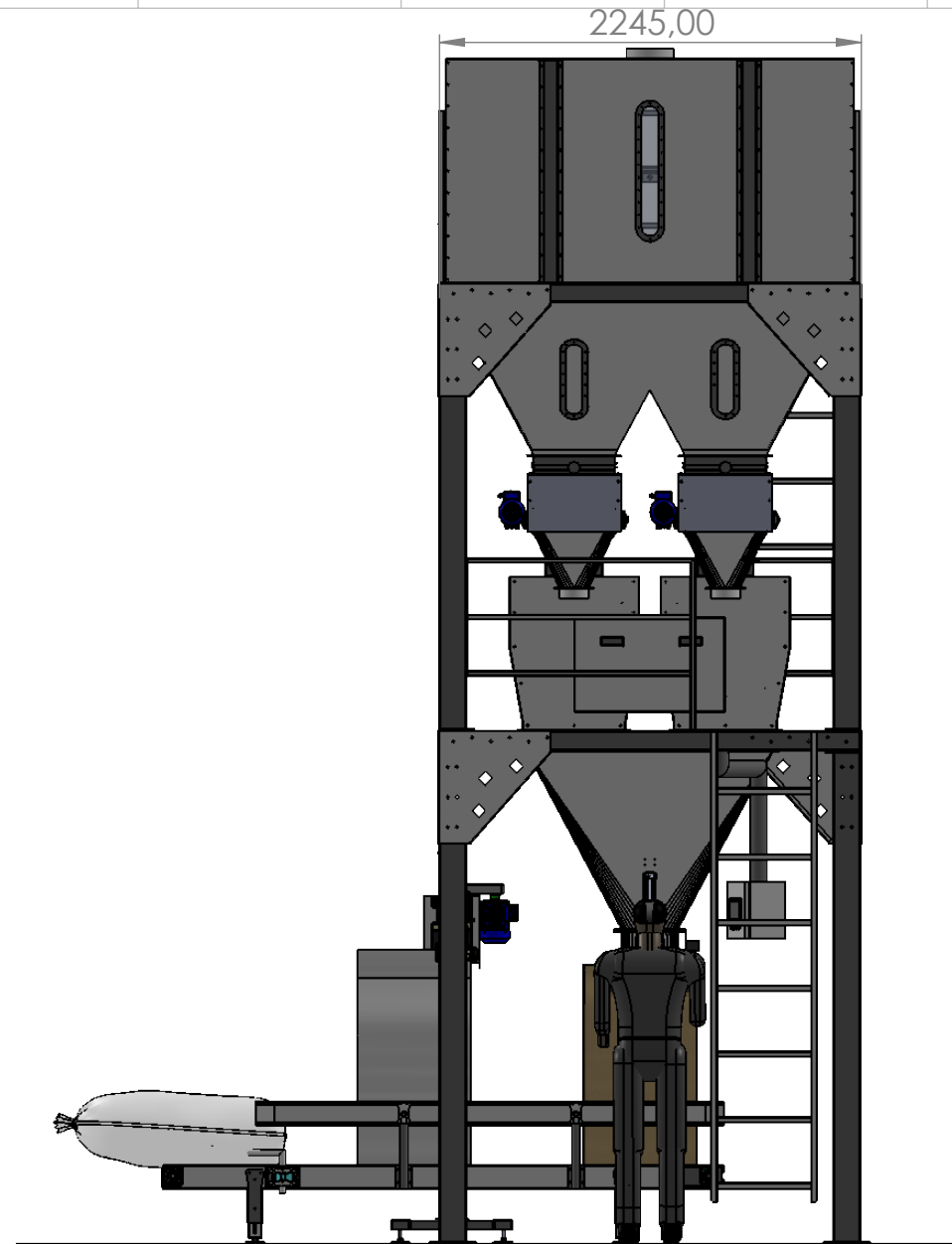

ÖN GÖRÜNÜM

MAKİNA ADI/NUMARASI:	YEM ÇUVALLAMA HATTI	SAYFA	A4	YASAL SAHİP:	
PARÇA ADI/NUMARASI:		ÖLÇEK	1:100		
ADET:	Aksi belirtilmedikçe tüm ölçüler: mm	TARİH	MALZEME:	Material"	Revizyon: İZDÜŞÜM YÖNTEMİ: 3.AÇI
ÇİZEN:		11.07.2023	AĞIRLIK:	Weight"	
KONTROL EDEN:	YUSUF TOKAT	11.07.2023	YÜZEY:	Finish"	
ONAYLAYAN:	YUSUF TOKAT	11.07.2023	RESİM NO:		

ÇUVAL TAŞIMA BANDI

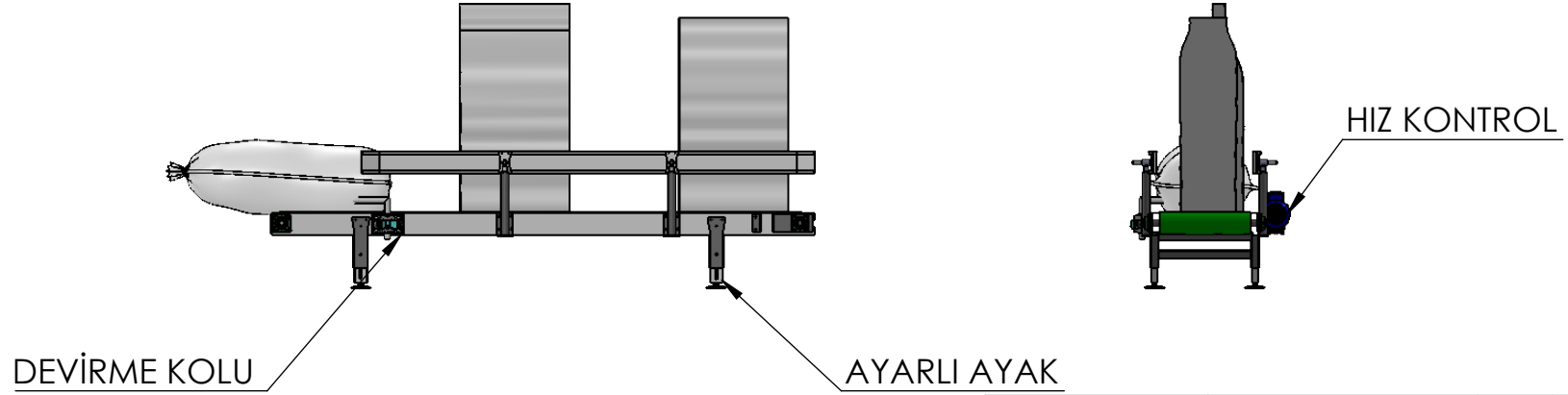
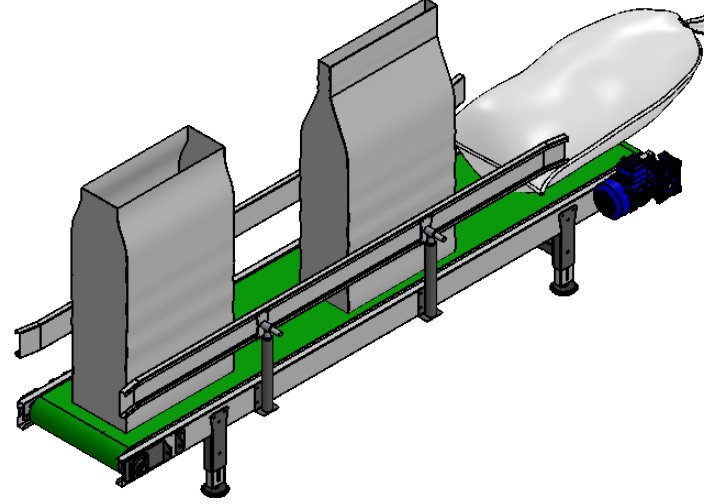

MAKİNA ADI/NUMARASI:	YEM ÇUVALLAMA HATTI	SAYFA	A4	YASAL SAHİP:	
PARÇA ADI/NUMARASI:		ÖLÇEK	1:100		
ADET:	Aksi belirtilmedikçe tüm ölçüler: mm	TARİH	MALZEME:	Material"	Revizyon: İZDÜŞÜM YÖNTEMİ: 3.AÇI
ÇİZEN:		11.07.2023	AĞIRLIK:	Weight"	
KONTROL EDEN:	YUSUF TOKAT	11.07.2023	YÜZEY:	Finish"	
ONAYLAYAN:	YUSUF TOKAT	11.07.2023	RESİM NO:		

DİKİŞ SÜTUNU

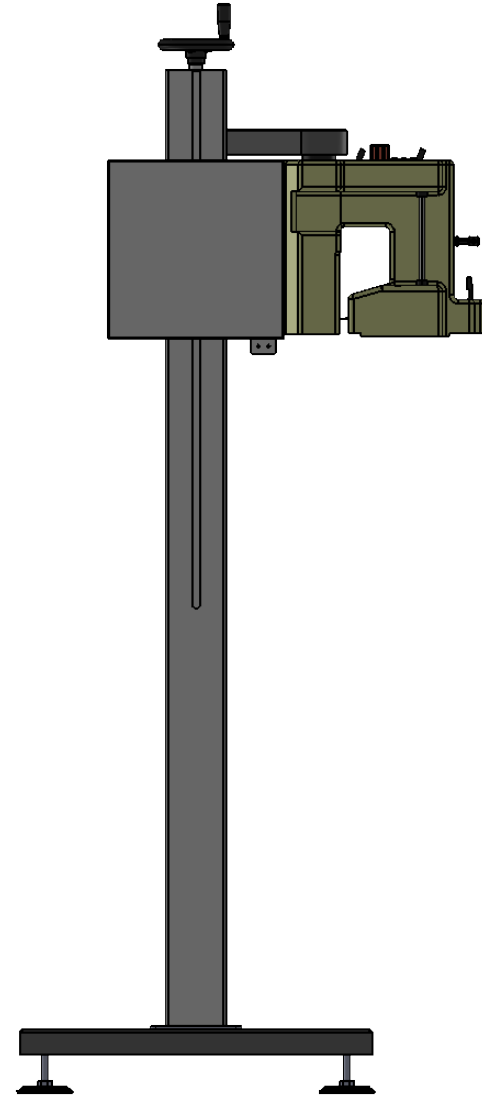
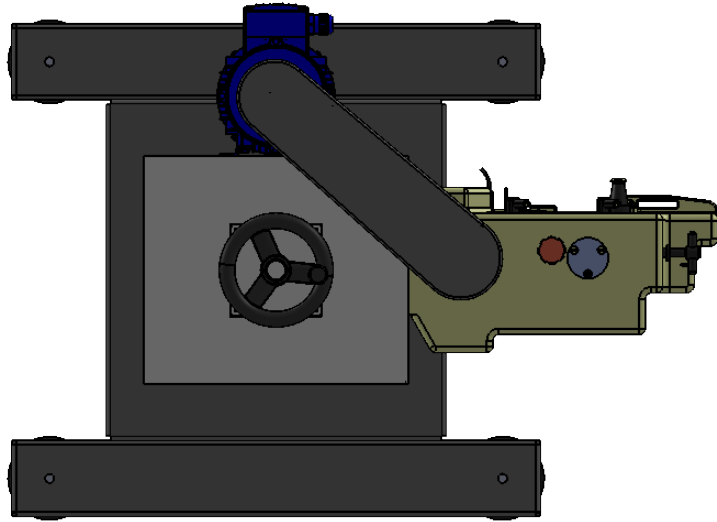

MAKİNA ADI/NUMARASI:	YEM ÇUVALLAMA HATTI	SAYFA	A4	YASAL SAHİP:	
PARÇA ADI/NUMARASI:		ÖLÇEK	1:100		
ADET:	Aksi belirtilmedikçe tüm ölçüler: mm	TARİH:	MALZEME:	Material:	Revizyon: İZDÜŞÜM YÖNTEMİ: 3.AÇI
ÇİZEN:		11.07.2023	AĞIRLIK:	Weight:	
KONTROL EDEN:	YUSUF TOKAT	11.07.2023	YÜZEY:	Finish:	
ONAYLAYAN:	YUSUF TOKAT	11.07.2023	RESİM NO:		